

MYA Series UPS 40-120kVA

Stock Code

002335.SZ

www.kehua.com

Kehua Data Co., Ltd.



High Reliability

- Wide input voltage and frequency range with high grid adaptability and prolong battery life.
- Separate internal air channel which hot air drives directly towards heat sink without distressing the PCB's and other internal sensitive components, improving the components service life and UPS reliability
- High overload capacity on inverter and bypass
- The most advanced and dual DSP control prevents single failure point and increase performance.
- Intelligent fan control and redundant design: 15% load can be driven when 2 fans fail and 40% load when 1 fan fails
- Integrated with input,output,bypass breaker and manual bypass switch for better protection of system.
- All-round conformal coating to all PCB boards, protect electronics from environmental effect and corrosion.
- Standard dust filter protect UPS placed in dusty environment.
- High short circuit capacity with time duration settable from 20~200ms which provide high protection for system.
- Cold start function which allow UPS start on battery when grid isn't available.
- Bus synchronization control function provides reliable high power for dual bus application
- Power walk in function decrease the inrush to mains or generator.
- Start up delay function, to sequentially restart the rectifiers once the mains power supply is restored if there are several UPS within the overall system
- No derating operate up to 40°C.

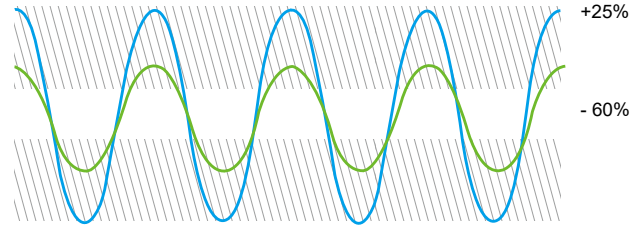

Wide input voltage range



Automatic fans control

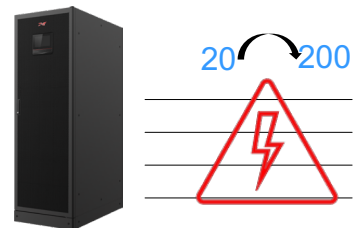

Short circuit time

- 1 Power unit
- 2 Bypass and control unit
- 3 Power distribution unit

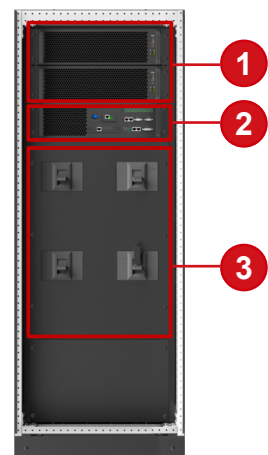



Green Power

- Latest generation IGBT and three level technology, Low harmonic, high efficiency, effectively energy-saving.
- High power density design, which small footprint on 120KVA only 0.6m² for saving installation space.
- High input power factor up to 0.99 and low Input THDi: < 3.0% at full load, much less grid pollution and costs
- AC/AC efficiency up to 94.5% and 30% load up to 94% efficiency reduces heat dissipation and limits power consumption costs
- ECO mode efficiency up to 98.3% lead to significant cost reduction
- W-ECO mode could reach 98% efficiency, THDi below 5% and transfer time below 4ms to reduce TCO.
- Self-load test function, easy debugging and easy onsite test during commissioning, before it is connected the real load, without using costly temporary loads, cabling and breakers for energy saving.
- Parallel ECO mode maximum whole system efficiency.
- Intelligent sleep mode which UPS sleep in random keep maximum efficiency and energy saving.
- 8 units of intelligent paralleling helps to achieve maximum capacity up to 960kW.

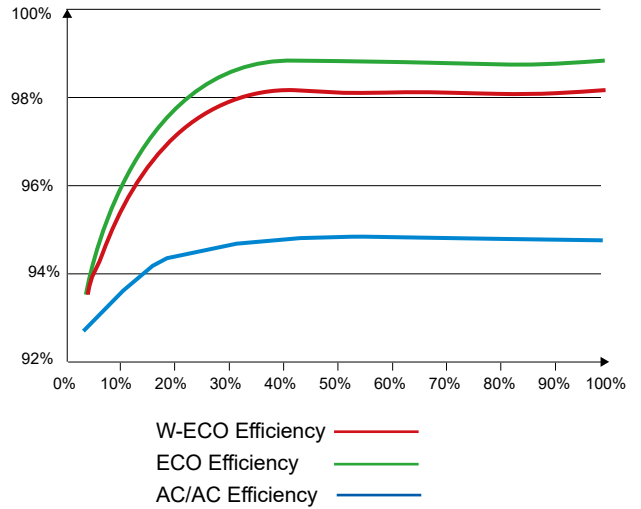

Intelligent Sleep Mode

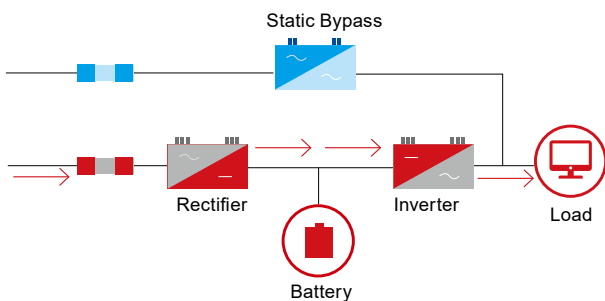

Double Conversion Mode

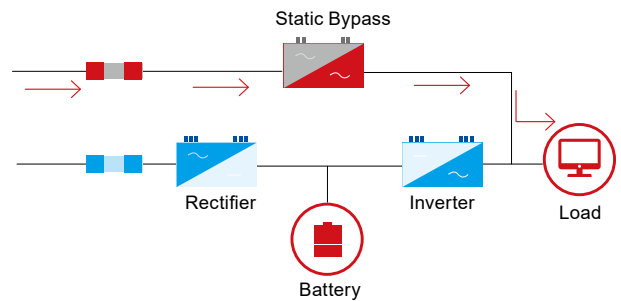

ECO Mode

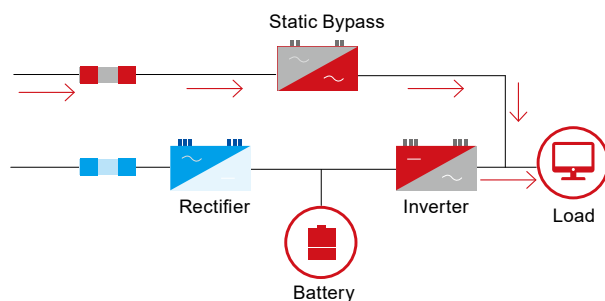

W-ECO Mode

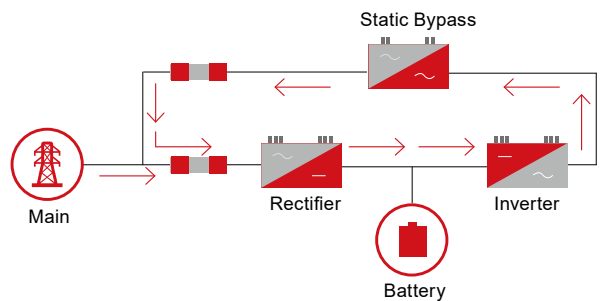

Self-load Test Mode

Intelligent Management

- Fault Trace Management (FTM) for convenient failure analysis(waveform record before & after of the fault point for 200ms) which easily figure out faulty point.
- 3 stage battery charging prolong the service life of batteries
- Intelligent battery management and mutiple setting, 28-48 pcs batteries per string allow customers to get the faulty battery out instead of replacing it
- Key components pre-alarm function which precaution the system fault and remind service for key components, like capacitor, fan.
- Full asset management record the spare parts replacement, timeline and service people.
- Cabinet temperature detect and pre-notification which prevent over temperature.
- Smart programmable dry contact which have 5 input dry contact and 3 output dry contact, which input dry contact have more than 10 functions and output dry contact have 18 functions allows to settable at site.
- Smart generator mode which allow UPS sent signal to turn on and off generator, also taking part power from battery to compensation generator capacity.
- Self-dedusting function which save the preventive service time.
- Common battery bank on parallel mode.
- Frequency converter function(60Hz to 50Hz or 50Hz to 60Hz)
- VRLA and Lithium battery compatible design

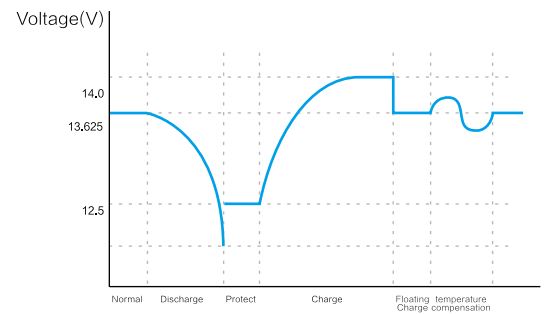
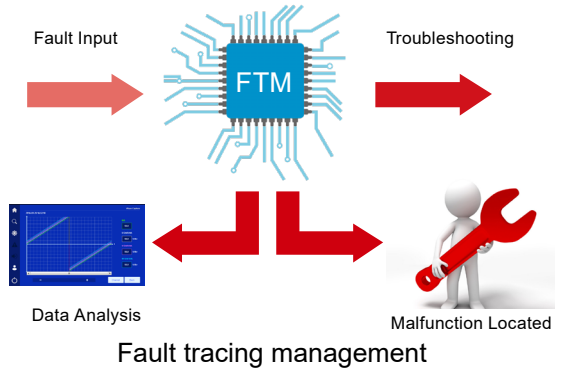

3 Stage Charging

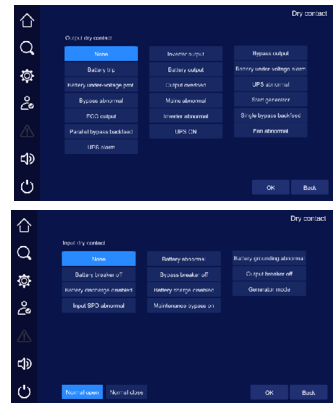

Programmable Dry Contact



Common battery bank



Frequency Converter Mode



User-friendly Interface

- User-friendly double physical ON/OFF button design to avoid false operation.
- User-friendly graphical interface with Single-line mimic diagram showing system status.
- Colorful 7" touch screen with LED Indicators, ensure comprehensive and visualized information display.
- Multi-language build-in display with Chinese, English, French, Spanish, Italian, Polish, Russian, Korean.
- High security access with separate password levels for users, technician and service engineers
- Large data storage capacity 10,000 pcs events logs.
- Support firmware online update, one time update for touch screen, power unit, bypass unit and extended card.
- Main unit display allow to check the information of each UPS status during parallel mode.



7" Touch Screen

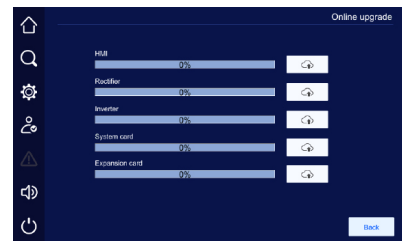

U disk Upgrade



More Options

- Flexible Network Management: SNMP
- Expanded dry contact kit (4 in 4 out)
- BMS kit for lithium battery communication
- Intelligent Battery Monitoring System
- Battery tripping kit
- N+X in parallel
- Input and output isolation transformer
- SPD: C Grade
- Battery Charge Temperature Compensation



BMS Kit



Extended Dry Contact Kit



C Level SPD



SNMP kit

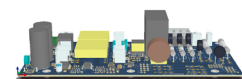

Battery tripping kit

Technical Specification

MODEL	MY40	MY50	MY60	MY80	MY100	MY120
INPUT						
Voltage (Vac)	70-155 (L-N) / 120-268 (L-L)					
Frequency (Hz)	40~70					
Power Factor	≥0.99					
Phase	3φ4W+PE					
THDi at full linear load	<3%					
BYPASS						
Bypass Voltage (Vac)	208±20%					
Frequency Range (Hz)	50/60(±5%/±10%)					
Overload	≤130%: long run; 130%< load ≤150%: 5min; 150%< load ≤200%: 1s; 200%< load≤300%: 100ms; >300%: immediately.					
OUTPUT						
Capacity (kVA)	40	50	60	80	100	120
Power Factor	1 (0.5 leading to 0.5 lagging)					
Voltage (Vac)	190/200/208/220±1%					
Frequency (Hz)	50/60±0.1% (Battery mode)					
Phase	3φ4W+PE					
Three Phase Difference	≤1%					
THDv	<1% (at linear load), <4% (at non-linear load)					
Waveform	Pure sine wave, THDv<1% at linear load,THDv<4% at non-linear load					
Transfer Time (ms)	0					
AC-AC Efficiency	up to 94%					
Overload	101-105% Long run, 106-110% load for 60 minutes, 111%-125% load for 10 minutes, 126%-150% load for 1 minute, over 150% load transfer to bypass					
BATTERY						
Battery Voltage (Vdc)	±144(±120~±144 adjustable)					
BATT Type	External					
Charging Current (A) MAX	30			60		
GENERAL						
Communication Interface	RS485, MODBUS, dry contact (RS232, BMS,SNMP, expend dry contact card are optional in slot)					
Display	7" touch screen+LED					
Alarm	AC input abnormal, low battery, overload, failure					
Protection	Output short-circuit, overload, over-temperature, battery low voltage, output over/low voltage					
Noise (dB)	<68					
Altitude(m)	0-2000 no derate					
IP	20					
Working Temperature (°C)	0 ~ 40 no derate,40~50 auto derate.					
Relative Humidity	0 ~ 95%, no condensation					
Dimension (W×D×H)(mm)	600×1000×1800					
Weight (kg)	161	161	161	260	260	260

• Specification is subject to change without prior notice.

Kehua Data Co., Ltd.

Add: No. 457, Malong Road, Torch High-Tech Industrial Zone, Xiamen Fujian China

Tel: +86-592-5160516 Fax: +86-592-5162166 www.kehua.com

